



FALL SHIELD™

STANDARD LIFT
DUAL TRACK

COMPANY		PREPARED BY	
EMAIL		PHONE NUMBER	
ADDRESS			
CITY		STATE	ZIP
PURCHASE ORDER NUMBER		DATE REQUIRED	QTY
TAG			
SPECIAL INSTRUCTIONS (Please note if this is for a quote)			

- A** Is there any interference for new track? Yes No
- B** Select One:
 - High lift the existing track 23 in
 - Allow chain link top panel to lean away from header
- C** Floor to Existing Horizontal Track: ____ ft ____ in
- D** Opening Width: ____ ft ____ in
- E** Opening Height: ____ ft ____ in
- F** Distance From Existing Track to Bollard: ____ in
- G** Outside to Outside of Existing Track: ____ ft ____ in
- H** Existing Door Width: ____ ft ____ in
- I** Existing Door Height: ____ ft ____ in
- J** Existing lower track is in good condition: Yes No
- K** Existing Track Width: 2 in 3 in
- L** Rasco door to be motorized: Yes No
- M** Required Fall Shield Height: ____ ft
(Minimum 4 ft)
- N** Panel Finish, Select One:
 - Powder Coat Yellow
 - Mill Finish
 - Custom Color _____
- O** Rasco Door Track Size: 2 in 3 in
(2" is recommended as it has a 32" radius to accommodate the unusually tall sections.)

✉ EMAIL SURVEY FORM TO RASCO

DOOR SIDE VIEW

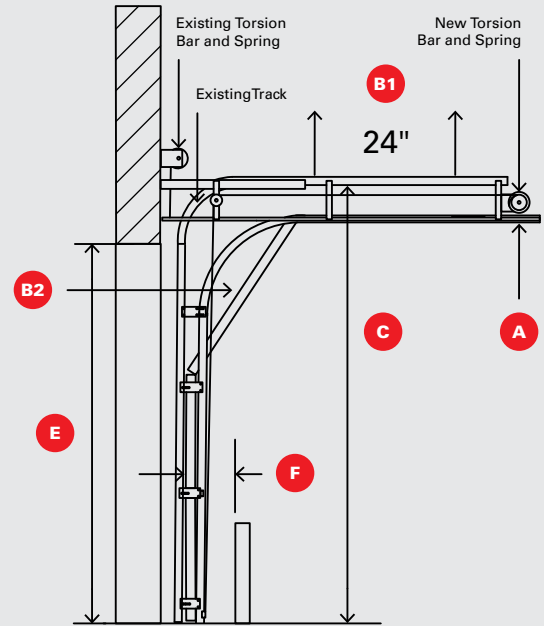

NOTES: A torsion bar support is required on all doors 10' or wider.
Switch track cannot be used if existing door has outside pull cables or has TKO, Workhorse or Barcol type tracks.
The Rasco door has outside pull brackets/cables.

DOORTOP ABOVE

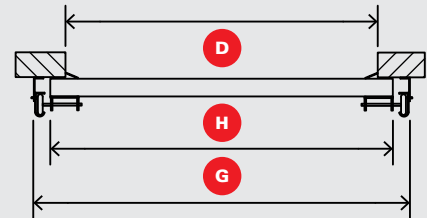

TRACKTOP DETAIL

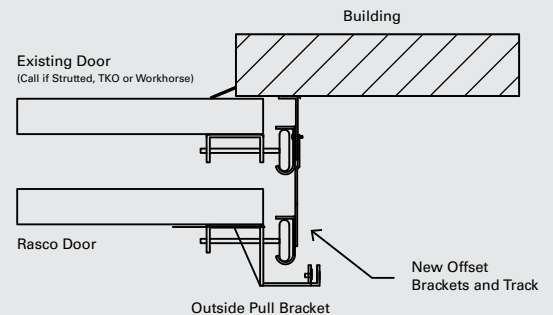

Measuring Guide



1

Track to bollard

To make sure you have clearance for your Rasco door.

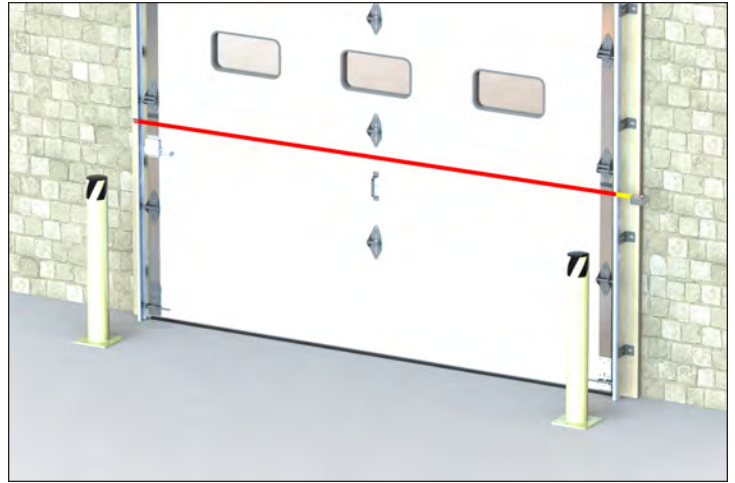

2

Outside to outside of existing track

To ensure a proper fit with your door.



3

Distance from wall to furthest part of existing track at top of the opening

To ensure a proper seal on the sides, many tracks are farther away from wall at top of opening.

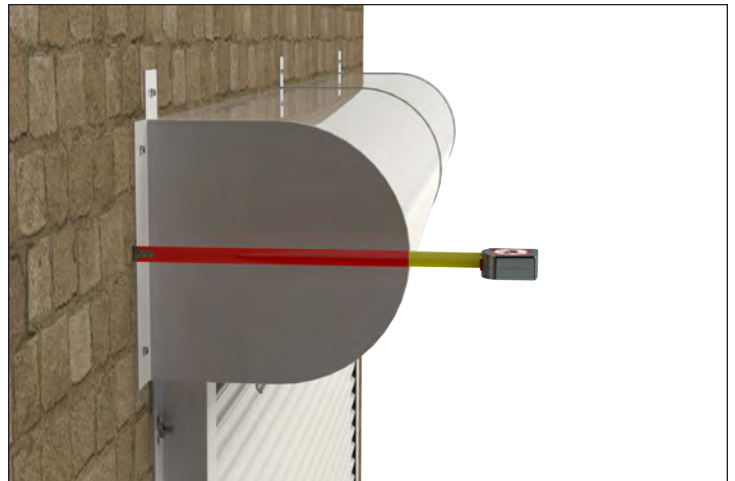

4

Wall to outside edge of roll or distance to back of roll

To ensure a tight seal on the sides.

09/30/24